

OPERATOR'S MANUAL

NM2322X-X

INCLUDING: SPECIFICATIONS, SERVICE KITS, GENERAL INFORMATION, TROUBLESHOOTING.
 INCLUDE MANUALS: 6710X-XXX Lower Pump End (PN 97999-600), 66915 Air Motor (PN 97999-748) and
 S-632 General Information Manual (PN 97999-624).

RELEASED: 10-17-97
REVISED: 1-31-18
(REV: F)

3" AIR MOTOR
22:1 RATIO
3" STROKE

NM2322X-X1-P4X

CHOP CHECK PUMP SERIES

Carbon Steel or Stainless Steel



READ THIS MANUAL CAREFULLY BEFORE INSTALLING, OPERATING OR SERVICING THIS EQUIPMENT.

It is the responsibility of the employer to place this information in the hands of the operator. Keep for future reference.
 The original language of this manual is English.

SERVICE KITS

- Use only genuine ARO® replacement parts to assure compatible pressure rating and longest service life.
- **637316** for repair of air motor section.
- **637290-P43** for repair of 67100-P43 lower pump ends.
- **637290-P48** for repair of 67100-P48 lower pump ends.
- **637291-P43** for repair of 67101-P43 lower pump ends.
- **637291-P48** for repair of 67101-P48 lower pump ends.

SPECIFICATIONS

Model Series (refer to option chart)	NM2322X-X1-P4X
Pump Type	Air Operated, Chop Check
Ratio	22:1
Air Motor	66915
Motor Repair Kit	637316
Motor Diameter	3" (7.62 cm)
Stroke (double acting)	3" (7.62 cm)
Air Inlet (female)	1/4 - 18 NPTF - 1
Lower Pump End Series	
NM2322E-11-P43	67100-P43
NM2322E-11-P48	67100-P48
NM2322E-71-P43	67100-P43
NM2322E-71-P48	67100-P48
NM2322F-11-P43	67101-P43
NM2322F-11-P48	67101-P48
NM2322F-71-P43	67101-P43
NM2322F-71-P48	67101-P48
Lower Pump Repair Kit	63729X-P4X
Material Outlet (female)	1/2 - 14 NPTF - 1
Weight	
NM2322X-11-P4X	29 lbs (13.2 kgs)
NM2322X-71-P4X	33 lbs (15.0 kgs)

PUMP PERFORMANCE

Air Inlet Pressure Range	30 - 150 psi (2.1 - 10.3 bar)
Fluid Pressure Range	660 - 3300 psi (45.5 - 227.6 bar)
Maximum Rec'd Cycles / Minute	120
Displacement Per Cycle	1.90 In ³ (31.1 cc)
Cycles Per Gallon	121.6
Flow @ 60 Cycles / Minute	0.5 gpm (1.9 lpm)
Noise Level @ 100 p.s.i.	85.0 db(A)Ⓣ
Accessories Available	61113 Wall Mount Bracket 66073-1 Air Line Connection Kit

Ⓣ The pump sound pressure level has been updated to an Equivalent Continuous Sound Level (LAeq) to meet the intent of ANSI S1.13-1971, CAGI-PNEUROPS S.1 using four microphone locations.

PUMP DATA

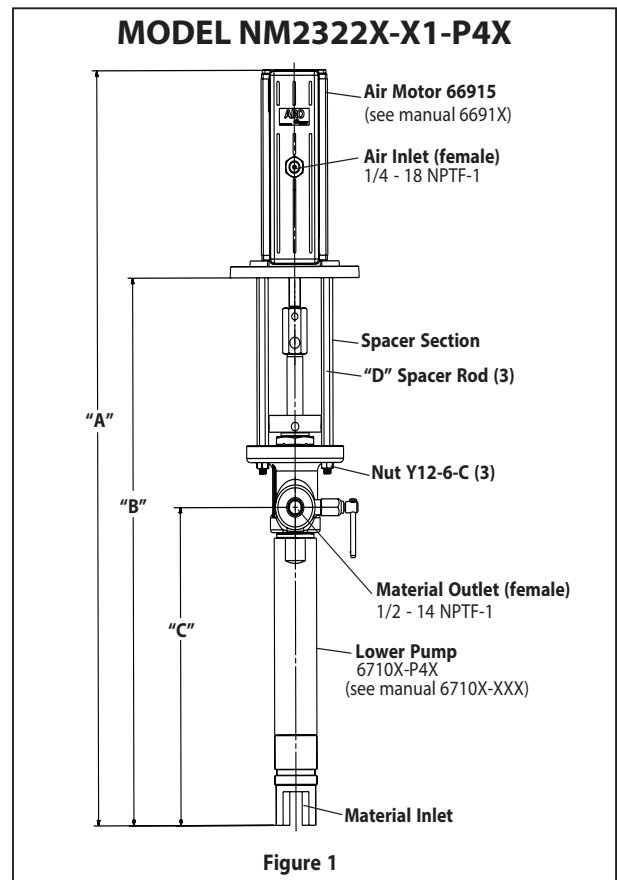

NOTE: Dimensions are shown in inches and (mm) and are supplied for reference only.

MODEL	"A" (mm)	"B" (mm)	"C" (mm)	"D" (mm)
NM2322X-11-P4X	33.70" (856.0)	24.44" (620.8)	14.19" (360.4)	93962
NM2322X-71-P4X	42.62" (1082.5)	33.34" (846.8)	14.19" (360.4)	93962-2

IMPORTANT

This is one of four documents which support the pump. Replacement copies of these forms are available upon request.

- NM2322X-X** Model Operator's Manual (pn 97999-755)
- S-632** General Information - Industrial Piston Pumps (PN 97999-624)
- 6710X-XXX** Lower Pump End Operator's Manual (PN 97999-600)
- 66915** Air Motor Operator's Manual (PN 97999-748)

PUMP OPTION DESCRIPTION CHART

NM2322 X - X1 - P 4 X



PUMP MATERIAL

E - Carbon Steel
F - Stainless Steel

PACKING MATERIAL

P - UHMW-PE / Glass Filled PTFE Staggered (upper)
UHMW-PE (lower)
F - UHMW-PE / Leather Staggered (upper)
UHMW-PE (lower)

SPRING ARRANGEMENT

4 - Multiple Wave Spring

PLUNGER TYPE

3 - Hardened Stainless Steel with Hard Chrome Plating
8 - Hardened Stainless Steel with Alternate Piston

GENERAL DESCRIPTION

- The chop-check design provides for easy priming of the lower foot valve. The double acting feature is standard in all ARO industrial pumps. Material is delivered to the pump discharge outlet on both the up and down stroke.
- A bleed valve is located on the lower pump body. This bleed valve allows trapped air to be vented from the pump.

⚠ WARNING HAZARDOUS PRESSURE. Do not exceed maximum operating pressure of 3000 psi (227.6 bar) at 150 psi (10.3 bar) inlet air pressure.

Pump Ratio X	=	Maximum Pump Fluid Pressure
Inlet Pressure to Pump Motor		

Pump ratio is an expression of the relationship between the pump motor area and the lower pump end area. EXAMPLE: When 150 psi (10.3 bar) inlet pressure is supplied to the motor of a 22:1 ratio pump, it will develop a maximum of 3000 psi (227.6 bar) fluid pressure (at no flow) - as the fluid control is opened, the flow rate will increase as the motor cycle rate increases to keep up with the demand.

⚠ WARNING Refer to general information sheet for additional safety precautions and important information.

NOTICE: Thermal expansion can occur when the fluid in the material lines is exposed to elevated temperatures. Example: Material lines located in a non-insulated roof area can warm due to sunlight. Install a pressure relief valve in the pumping system.

Replacement warning label (pn 94520) is available upon request.

TROUBLE SHOOTING

Pump problems can occur in either the air motor section or the lower pump end section. Use these basic guidelines to help determine which section is affected. Be sure to eliminate any possible non-pump problems before suspecting pump malfunction.

Pump will not cycle.

- No pressure to the motor. See motor manual.
- Restricted return lines. Clean obstruction.
- Damaged motor. Service the motor.

No material at the outlet (pump continually cycles).

- Check the material supply, disconnect or shut off the air supply and replenish the material, reconnect.

Material on one stroke only (fast downstroke).

- The lower check may not be seating in the foot valve (see lower pump disassembly). Remove the check from the foot valve, clean and inspect the valve seat area. If the check or foot valve are damaged, replace.

Material on one stroke only (fast upstroke).

- The middle packings may be worn (see lower pump disassembly). Replace the seals as necessary.

Material leakage out of the solvent cup or material appears on the pump plunger rod.

- Tighten the solvent cup until leakage discontinues. If this procedure does not aid in stopping the leakage problem, the upper packings may be worn (see lower pump disassembly). Replace the seals as necessary.

PUMP CONNECTION - UPPER / LOWER

DISASSEMBLY

NOTE: All threads are right hand.

- Lay the pump assembly on a workbench.
- Remove the three (Y12-6-C) nuts from the three "D" spacer rods (see figure 1).
- Pull the air motor from the lower pump end until motor piston rod is in the "down" position and lower pump end rod is in "up" position.
- Unscrew three spacer rods (see figure 1) from the airmotor assembly.
- Remove two (Y15-22-S) cotter pins and remove (93985 and 94048) pins. Remove (93961-X) connector.

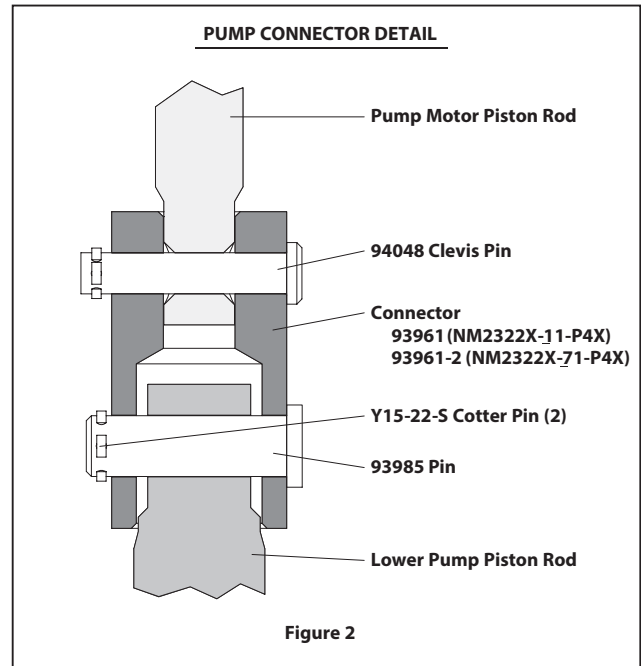

Figure 2

REASSEMBLY

- Align the pumpmotor with the lower pump end. Position the air inlet of the motor in line with the lower pump material outlet.
- Position (93961-X) connector in place and insert (93985 and 94048) pins into connector. Use two (Y15-22-S) cotter pins to retain connector.
- Screw three (93962-X) spacer rods into air motor lower plate.
- Bring the motor and lower pump together, aligning spacer rods with holes in lower pump body. Assemble three nuts (Y12-6-C) to spacer rods, securing assembly.